

High Temperature Pressure Transmitter with Cooling Fins

SKL

Main features

- Measuring ranges 0...1 bar to 0...2000 bar
- All standard signals for industry, hydraulics and pneumatics
- Media temperature range -40°C to 180°C
- Ambient temperature range -40°C to 105°C
- Shock and vibration-resistant > 1000 g shock, > 20 g vibration
- No internal transmitting media (fully welded, "dry" measuring cell)
- Degree of protection from IP65 (special version up to IP69K)
- Compact and robust stainless steel design
- Precision class 0.5 %

Applications

- General industrial applications
- Automotive engineering
- Hydraulics
- Pneumatics
- Plant engineering and automation

Description

The SKL with cooling fins has been designed for applications with higher temperature requirements. Thanks to its stainless steel diaphragm and semiconductor thin-film technology, this pressure transmitter has excellent properties.

The stainless steel diaphragm is fully vacuum-tight, extremely burst-resistant and applicable with all standard media in automotive engineering, hydraulics, pneumatics, etc., as long as they are compatible with stainless steel. Its robust design guarantees high reliability also in rugged conditions. Its modular design offers a variety of signal, thread and connecting options.

The SKL series is suited for application in environments exposed to high thermal load.



Specification

PRESSURE RANGE								
Measuring range*	p [bar]	1,0	1,6	2,0	2,5	4,0	6,0	10,0
Overload pressure	p [bar]	6	6	6	6	10	20	20
Burst pressure	p [bar]	9	9	9	9	15	30	30
Measuring range*	p [bar]	16	20	25	40	60	100	160
Overload pressure	p [bar]	40	40	100	100	200	200	400
Burst pressure	p [bar]	60	60	150	150	300	300	600
Measuring range*	p [bar]	200	250	400	600	1000	1600	2000
Overload pressure	p [bar]	400	750	750	840	1200	2400	2400
Burst pressure	p [bar]	600	1000	1000	1050	1500	3000	3000
ELECTRICAL PARAMETER								
		signal			U_s [V _{DC}]	R_L [k Ω]		R_A [Ω]
Output signal * and maximum acceptable burden R_A	R_A in Ohm	4...20 mA (2-wire, 3-wire)			9...32			acc. to $R_A = < (U_s - 10V) / 0,02 A$
		0...10 V _{DC} (3-wire)			12...32	> 5,0		
		1...5 V _{DC}			8...32	> 1,0		
		0,5...4,5 V _{DC} ratiometric			5 \pm 10%	> 4,7		
Response time * (10-90%)	t [ms]	< 1						
Withstand voltage	U [V _{DC}]	350	option 710					
ACCURACY								
Accuracy @RT	% of the range	$\leq 0,50^{**}$						
	BFSL	$\leq 0,125$						
Non-linearity	% of the range	$\leq 0,15$						
Repeatability	% of the range	$\leq 0,10$ ** incl. nonlinearity, hysteresis, repeatability, zero-offset- and final-offset						
Stability/year	% of the range	$\leq 0,10$ (acc. to IEC 61298-2)						
ACCEPTABLE TEMPERATURE RANGES								
Measuring medium, always	T [°C]	-40...160						
Measuring medium, up to 15 min		-40...180						
Ambience	T [°C]	-40...105						
Storage	T [°C]	-40...105						
Compensated range*	T [°C]	-20...85						
Temperature coefficient within the compensated range								
Mean TC offset	% of the range	$\leq 0,15 / 10K$						
Mean TC range	% of the range	$\leq 0,15 / 10K$						
Total error	% of the range	-40°C		2,00%				
	% of the range	105°C		2,00%				
MECHANICAL PARAMETER								
Parts in contact with the measuring medium*		stainless steel						
Housing*		stainless steel						
Shock resistance	g	1000	acc. to IEC 68-2-32					
Vibration resistance	g	20	acc. to IEC 68-2-6 and IEC 68-2-36					
Mass	m [g]	~ 250	(depending on design)					
CE - conformity		EC Directive 89/336/EWG						
IP system of protection		The IP system of protection as specified in the data sheets generally applies, with their mating plug connected. Relative pressure transmitters usually require a ventilated mating plug and/or cable to allow for pressure compensation. From a pressure range of 60bar, a ventilated mating plug and/or cable is not necessarily required.						
* others upon request								

Configuration -example-

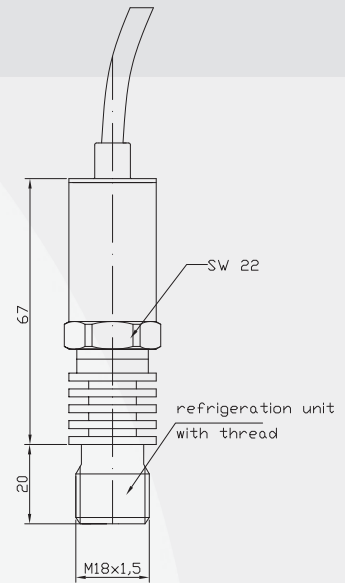

Connectors*

MVS/A
DIN EN 175301-803

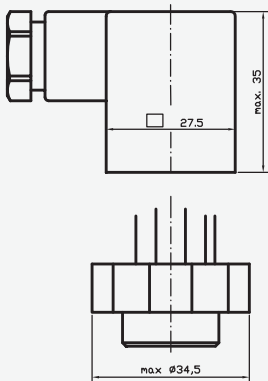

MVS/C
DIN EN 175301-803

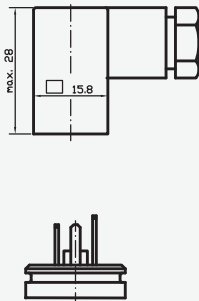

male socket
M12x1 (S 763)

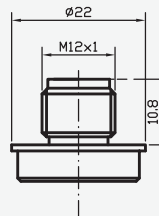

Cable output
steel

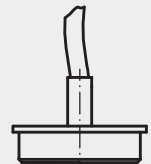

Pressure Connections*

G 1/4 A; DIN 3852; Form E G 1/4 B

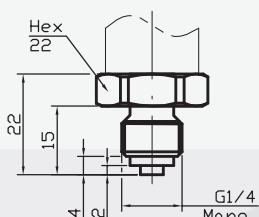
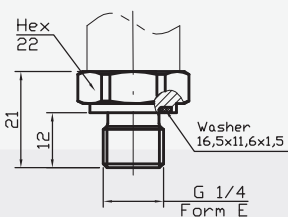

G 1/2 B

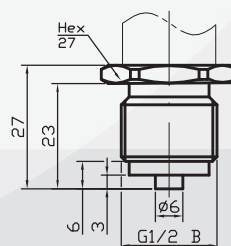

1/4 NPT

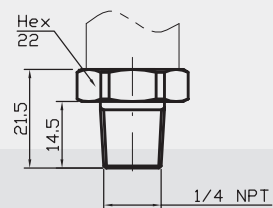

M18x1,5

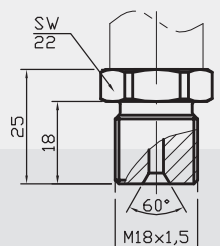

* Custom-made adjustments acc. to pressure connections and connecting options are possible.

SKL

High Temperature Pressure Transmitter with Cooling Fins

Electrical Connections* (left: 2-wire, right: 3-wire)

MVS/A
DIN EN
175301-803

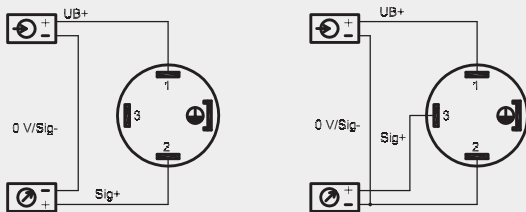

male
socket
M12x1
(S 763)

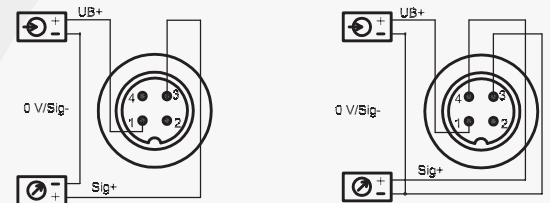

MVS/C
DIN EN
175301-803

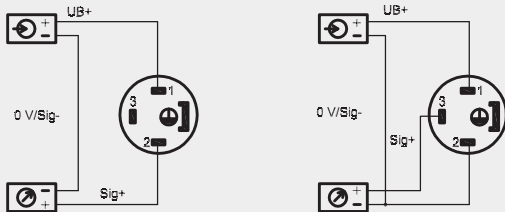

cable
output

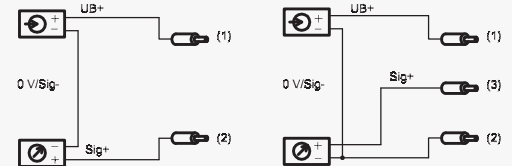

Legend

= power supply
 = consumer

⟨1⟩ = red
⟨2⟩ = black
⟨3⟩ = white

* Custom-made adjustments acc. to pressure connections and connecting options are possible.

Product line

DS4	Electronic Pressure Switch	SMC	Pressure Transmitter with CANopen Interface
DPSX9I	Intrinsically Safe Electronic Pressure Switch for Current	SME	Pressure Transmitter in Miniature Design
DPSX9U	Intrinsically Safe Electronic Pressure Switch for Voltage	SMF	Pressure Transmitter with Flush Diaphragm
PS1	Level Sensor	SMH	High Pressure Transmitter
PSX2	Intrinsically Safe Level Sensor	SML	Pressure Transmitter for Industrial Application
SHP	High Precision Pressure Transmitter	SMO	Pressure Transmitter in Mobile Hydraulics
SIS	Low Pressure Transmitter in Short and Compact Design	SMS	OEM Pressure Transmitter for Hydraulics and Pneumatics
SIL	Low Pressure Transmitter for Industrial Application	SMX	Intrinsically Safe Pressure Transmitter for Industrial Application
SKE	High Temperature Pressure Transmitter with Detached Electronics	TPS	Multi-Function Transmitter for Pressure and Temperature
SKL	High Temperature Pressure Transmitter with Cooling Fins		



GUEMISA (Electrónica Guerra y Miró Guemisa S.L.)
Sta. Virgilia, 29 - local - 28033 Madrid (Spain)
Tlfn.: (034) 91 764 21 00 Fax.: (034) 91 764 21 32
Email.: ventas@guemisa.com Web.: www.guemisa.com